

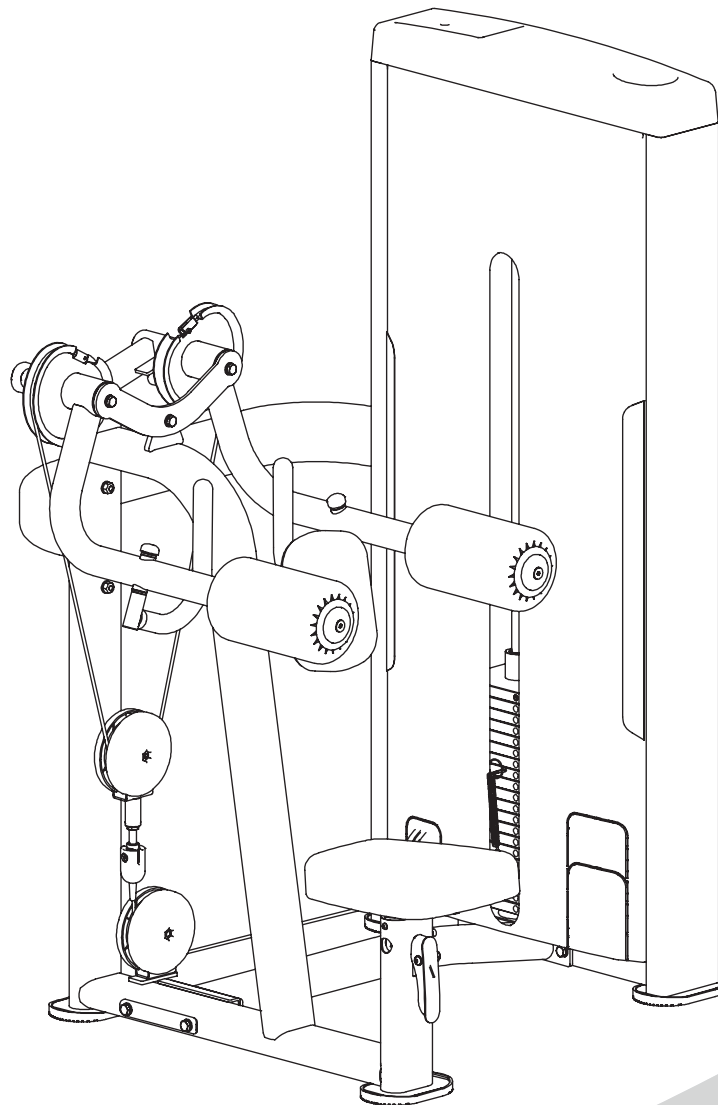

DSA034E

LATERAL RAISE

# OWNER'S MANUAL



## **! CAUTION**

Read all precautions  
and instructions in this manual  
before using this equipment

Read all precautions and instructions in this manual before using this equipment.

## Table Of Contents

|                                      |    |
|--------------------------------------|----|
| Important Safety Instructions-----   | 3  |
| Instructions-----                    | 4  |
| Parts List-----                      | 5  |
| Exploded View-----                   | 6  |
| Measurement Guide-----               | 7  |
| Assembly Instructions-----           | 8  |
| Assembly-----                        | 9  |
| Maintenance Schedule-----            | 13 |
| General Maintenance Information----- | 14 |
| Weight Training Tips-----            | 15 |

## Important Safety Instructions

Before beginning any fitness program, you should obtain a complete physical examination from your physician. When using exercise equipment, basic precautions should always be taken, including the following:

1. Read all instructions before using the equipment.  
These instructions are written to ensure your safety and to protect the unit.
2. Use the equipment only for its intended purpose as described in this guide.  
Do not use accessory attachments that are not recommended by the manufacturer: such attachments might cause injuries.
3. The product should only be used on a level surface and is with 0.5 meters space around the product.  
Do not use the equipment outdoors.
4. Do not allow children on or near the equipment. And children are not allowed to use this equipment.  
Teenagers should use this equipment with adult supervision.
5. Do not overexert yourself or work to exhaustion.  
Do not attempt to lift more weight than you can control safely.  
If you feel any pain or abnormal symptoms, stop your workout immediately and consult your physician.
6. This equipment is not used as medical apparatus and instruments.
7. Never operate the unit when it has been dropped or damaged.  
Never drop or insert anything into any opening in the equipment.  
Always check the unit and its cables before each use. Make sure that all fasteners and cables are secure and in good working condition.  
Frayed or worn cables can be dangerous and may cause injury. Periodically check these cables for any indication of wear.  
Keep hands, limbs, loose clothing and long hair well out of the way of moving parts.
8. Be careful when getting on or off the equipment.
9. Wear proper exercise clothing and shoes for your workout, no loose clothing.

## Instructions

Before beginning assembly please take the time to read instructions thoroughly. Please use the various lists in this manual to make sure that all parts have been included in your shipment. When ordering, use part number and description from the lists. Use only our replacement part when servicing. Failure to do so will void your warranty and could result in personal injury.

The equipment is designed to provide the smoothest, most effective exercise motion possible. After assembly, you should check all functions to ensure correct operation. If you experience problems, first recheck the assembly instructions to locate any possible errors made during assembly. If you are unable to correct the problem, call your authorized dealer. Be sure to have your serial number and this manual when calling. When all parts have been accounted for, continue on.

## Tools Required

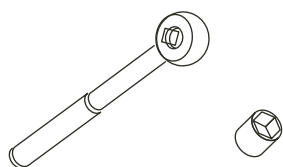

Ratchet Wrench and Socket

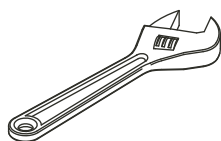

Adjustable Wrench

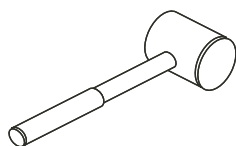

Rubber Mallet

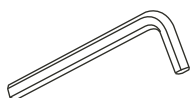

Hex Key Wrench Set

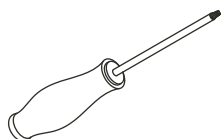

Phillips Screwdriver

# Parts List

**NOTE: SOME OF THESE PARTS MAY COME PRE-INSTALLED.**

| Item No. | Description                                    | QTY | Item No. | Description   | QTY |
|----------|--|-----|----------|---|-----|
| 1        | Weight Stack Frame ASSY                        | 1   | 14       | Cable Connector   | 1   |
| 1.1      | Weight Stack Frame                             | 1   | 18       | Chest Pad   | 1   |
| 1.2      | Guide Rod                                      | 2   | 19       | Seat Pad  | 1   |
| 1.3      | Pulley Block                                   | 2   | 20       | Foam Pad  | 2   |
| 1.4      | Fixing Sleeve                                  | 2   | 21       | Aluminum Cap  | 2   |
| 1.5      | Bushing  | 2   | 22       | Aluminum Grip Ring  | 4   |
| 1.6      | Foot Cover                                     | 2   | 23       | Spring  | 1   |
| 1.7      | Plug F38                                       | 1   | 25       | 4.5" Pulley   | 2   |
| 1.8      | 4.5" Pulley                                    | 2   | 26       | Pulley Cover  | 4   |
| 1.9      | Pulley Cover                                   | 3   | 27       | Plastic Tube Guide  | 2   |
| 1.11     | Top Plate                                      | 1   | 28       | Foot Plate  | 2   |
| 1.12     | Selector Pin W/Coil                            | 1   | 31       | Grip  | 2   |
| 1.13     | Weight Rubber Bumper                           | 2   | 33       | Stop Coller   | 4   |
| 1.14     | Front Shroud                                   | 1   | 34       | Nut Cap   | 2   |
| 1.15     | Top Shroud                                     | 1   | 36       | Cable 1   | 1   |
| 1.16     | Rear Shroud                                    | 1   | 37       | Cable 2   | 1   |
| 1.17     | Shroud Hanger                                  | 8   | 38       | Washer $\phi 27.6 \times \phi 22 \times \phi 12.5 \times 3.5$ | 2   |
| 1.18     | Sticker  | 4   | 39       | Bushing   | 4   |
| 1.20     | Hex Head Screw M10 $\times$ 80                 | 1   | 40       | Bearing $\phi 50.8 \times \phi 25.4 \times 15.9$              | 4   |
| 1.22     | Hex Head Screw M10 $\times$ 50                 | 1   | 44       | Hex Flanged Nut M12   | 1   |
| 1.23     | Socket Head Cap Screw M10 $\times$ 50          | 1   | 45       | Retainning Snap Ring $\phi 12$                                | 2   |
| 1.24     | Cross Pan Head Screws M5 $\times$ 15           | 20  | 47       | Hex Nut M6  | 2   |
| 1.30     | Nylon Lock Nut M10                             | 3   | 48       | Hex Head Bolt M10 $\times$ 130                                | 2   |
| 1.33     | Flat Washer $\phi 10 \times \phi 5.3 \times 1$ | 4   | 49       | Hex Head Bolt M10 $\times$ 90                                 | 2   |
| 1.34     | Flat Washer $\phi 20 \times \phi 11 \times 2$  | 3   | 51       | Hex Head Bolt M10 $\times$ 70                                 | 2   |
| 1.37     | Socket Head Cap Screw M8 $\times$ 25           | 2   | 53       | Hex Head Bolt M10 $\times$ 30                                 | 6   |
| 1.38     | Flat Washer $\phi 9 \times \phi 16 \times 1.6$ | 2   | 54       | Hex Head Bolt M10 $\times$ 20                                 | 3   |
| 1.39     | Spring Washer $\phi 8$                         | 2   | 55       | Socket Head Cap Screw M10 $\times$ 50                         | 2   |
| 1.49     | Rubber Bumper                                  | 2   | 56       | Socket Head Cap Screw M8 $\times$ 25                          | 1   |
| 1.50     | Reed Nut M5                                    | 4   | 57       | Socket Head Cap Screw M4 $\times$ 15                          | 2   |
| 2        | Main Frame                                     | 1   | 58       | Flat Head Cap Screw M10 $\times$ 30                           | 2   |
| 3        | Bottom Cross Brace                             | 1   | 59       | Button Head Cap Screw M8 $\times$ 45                          | 1   |
| 4        | Rear Cross Brace                               | 1   | 60       | Button Head Cap Screw M6 $\times$ 12                          | 2   |
| 5        | Left Press Arm                                 | 1   | 63       | Nylon Lock Nut M10  | 8   |
| 6        | Right Press Arm                                | 1   | 64       | Nylon Lock Nut M8   | 1   |
| 7        | Seat Pad Support                               | 1   | 66       | Flat Washer $\phi 20 \times \phi 11 \times 2$                 | 21  |
| 8        | Connection Plate                               | 1   | 67       | Flat Washer $\phi 16 \times \phi 9 \times 1.6$                | 2   |
| 9        | Haddle Frame                                   | 2   | 71       | Lube  | 1   |
| 10       | Adjustable Floating Pulley Assembly            | 1   | 72       | Spring Washer $\phi 10$                                       | 2   |
| 11       | Adjustable Support                             | 1   | 73       | Socket Set Screw M6 $\times$ 16                               | 2   |

# Exploded View

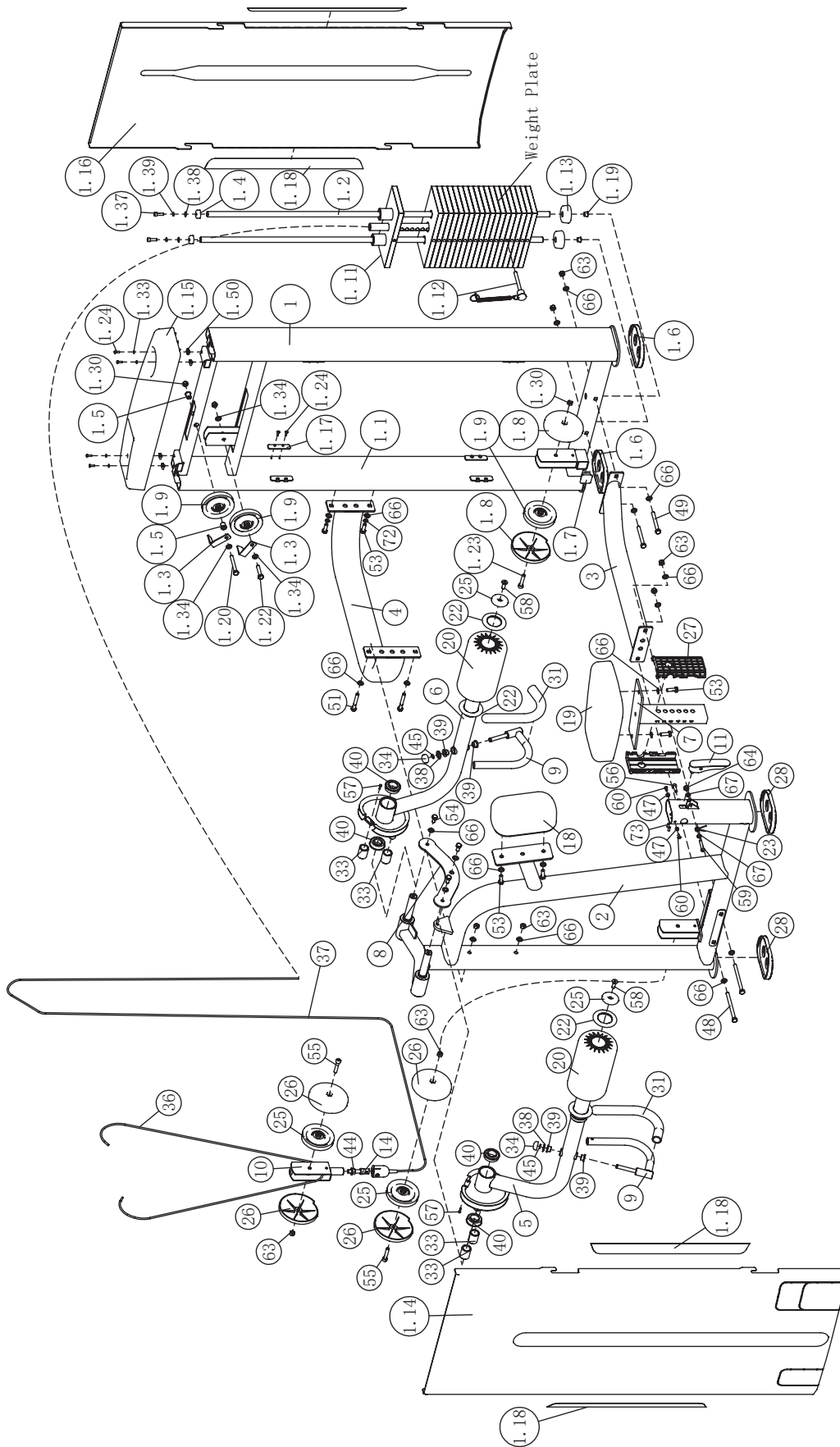

# Measurement Guide

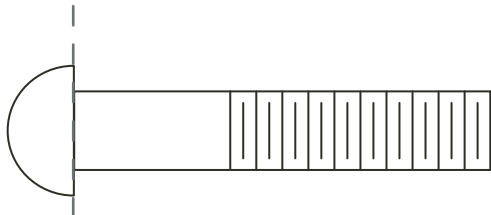

BHCS = Button Head Cap Screw

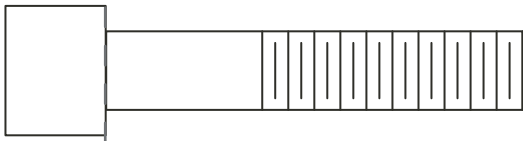

SHCS = Socket Head Cap Screw

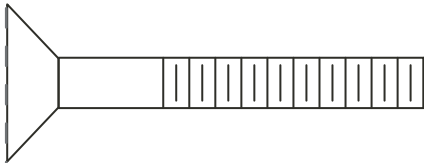

FHCS = Flat Head Cap Screw

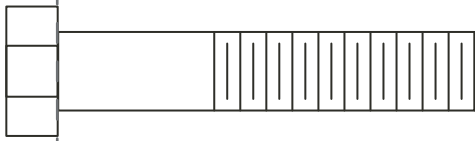

HHB = Hex Head Bolt

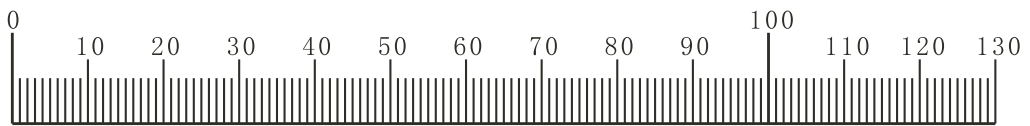

Millimeters



Inches

## Assembly Instructions

Assembly of the equipment takes professional installers about 2 hours. If this is the first time you have assembled this type of equipment, plan to spend more time. It is strongly recommended to assemble the equipment by professional installers. You may find it quicker, safer, easier to assemble this equipment with the help of a friend, as some of components may be large, heavy or awkward to handle alone. It is important that you assemble your product in a clean, clear, uncluttered area. This will enable you to move around the product while you are fitting components and reduce the possibility of injury during assembly.

### **NOTE**

As with any assembled part, proper alignment and adjustment is critical. While tightening the fasteners, be sure to leave room for adjustments. Do not fully tighten the fasteners until instructed to do so. Be careful to assemble the components in the sequence presented in this guide.

# Assembly

## STEP 1

**Note: Hand Tighten Bolts and Nylon Lock Nuts.**

| Item No. | Description             | QTY | Item No. | Description           | QTY |
|----------|-------------------------|-----|----------|-----------------------|-----|
| 1        | Weight Stack Frame ASSY | 1   | 51       | Hex Head Bolt M10×70  | 2   |
| 2        | Main Frame              | 1   | 53       | Hex Head Bolt M10×30  | 2   |
| 3        | Bottom Cross Brace      | 1   | 63       | Nylon Lock Nut M10    | 6   |
| 4        | Rear Cross Brace        | 1   | 66       | Flat Washer φ20×φ11×2 | 14  |
| 48       | Hex Head Bolt M10×130   | 2   | 72       | Spring Washer φ10     | 2   |
| 49       | Hex Head Bolt M10×90    | 2   |          |                       |     |

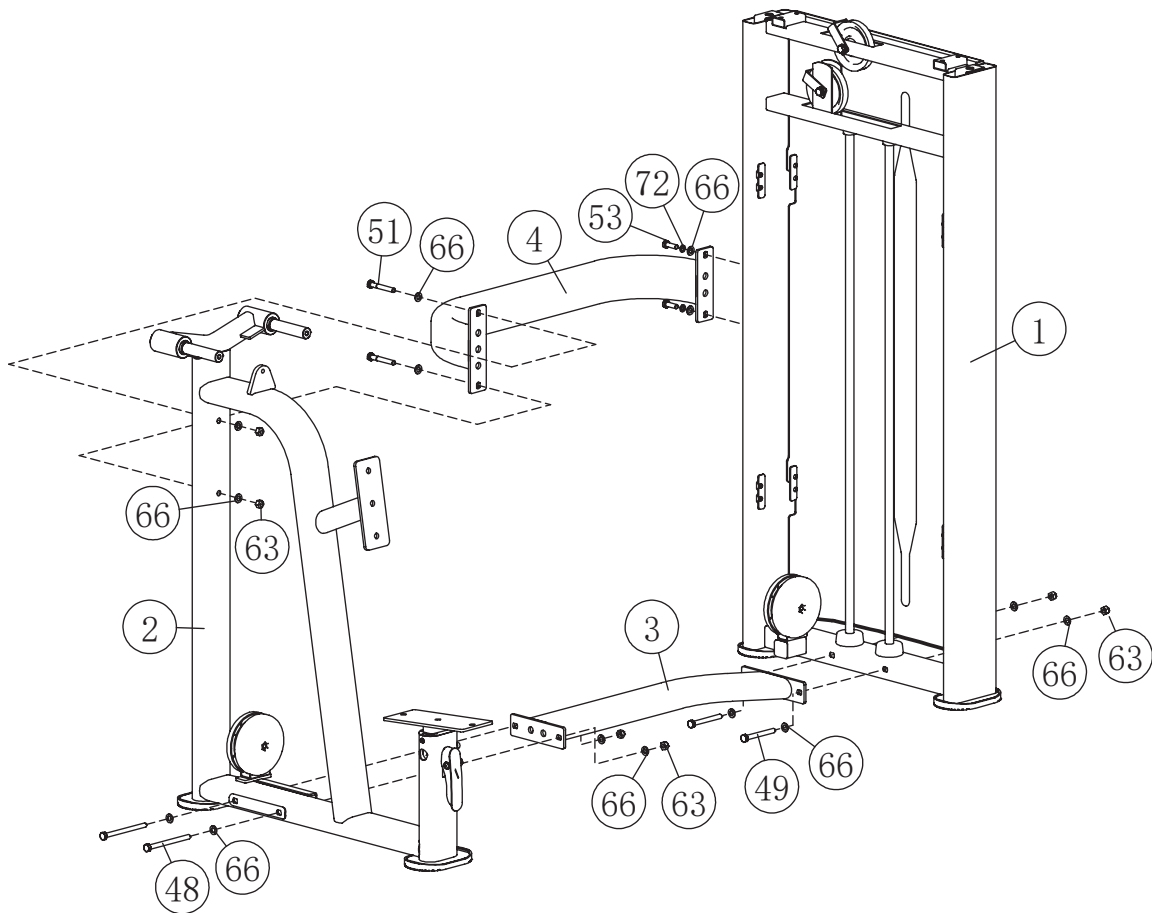

# Assembly

## STEP 2

**Note: Hand Tighten Bolts and Nylon Lock Nuts.**

| Item No. | Description     | QTY |
|----------|-----------------|-----|
| 5        | Left Press Arm  | 1   |
| 6        | Right Press Arm | 1   |

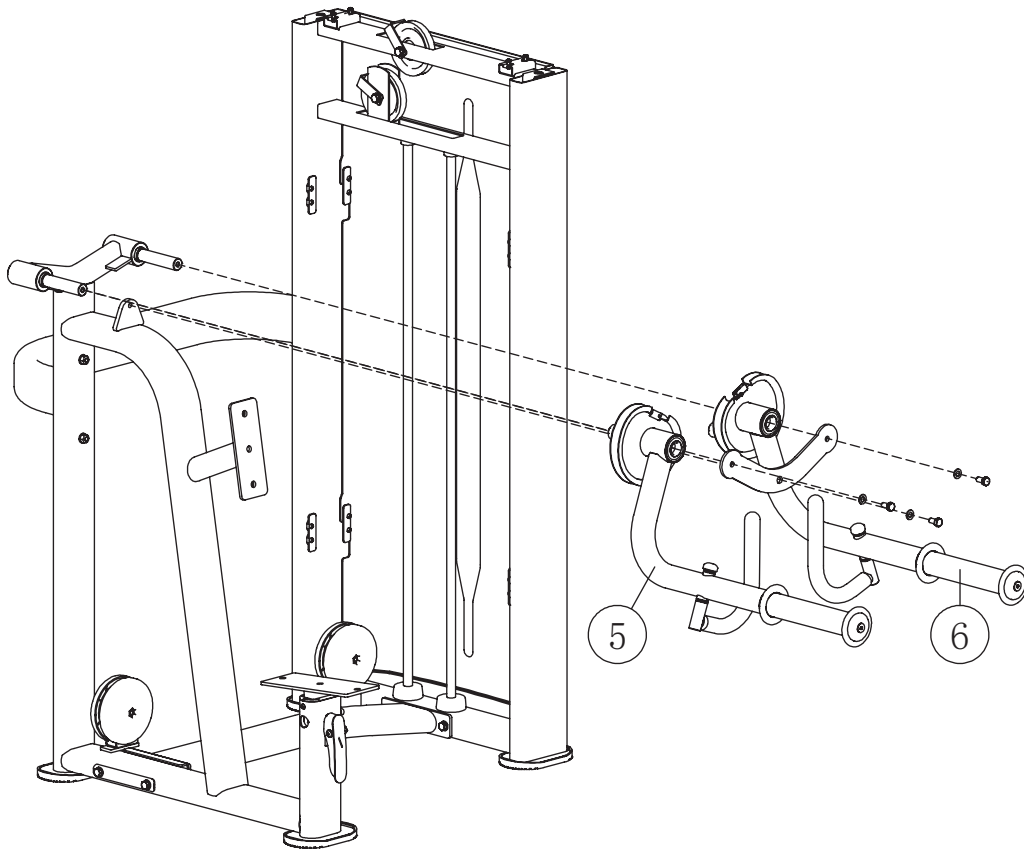

# Assembly

## STEP 3

**Note: Hand Tighten Bolts and Nylon Lock Nuts.**

| Item No. | Description                         | QTY |
|----------|-------------------------------------|-----|
| 10       | Adjustable Floating Pulley Assembly | 1   |
| 36       | Cable 1                             | 1   |
| 37       | Cable 2                             | 1   |

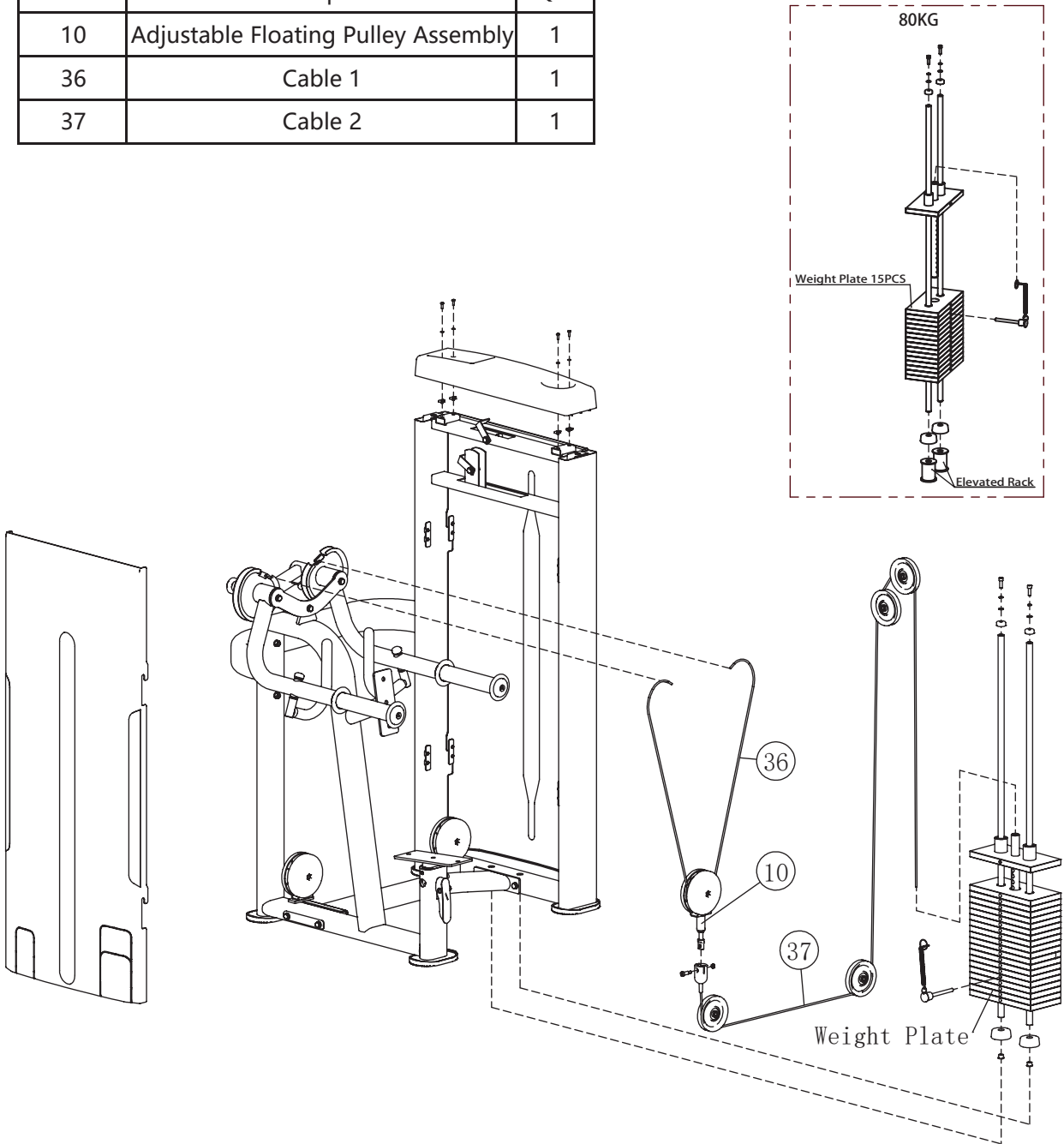

# Assembly

## STEP 4

**Note: Wrench Tighten Screws.**

| Item No. | Description | QTY | Item No. | Description           | QTY |
|----------|-------------|-----|----------|-----------------------|-----|
| 18       | Chest Pad   | 1   | 53       | Hex Head Bolt M10×30  | 4   |
| 19       | Seat Pad    | 1   | 66       | Flat Washer φ20×φ11×2 | 4   |
| 20       | Foam Pad    | 2   |          |                       |     |

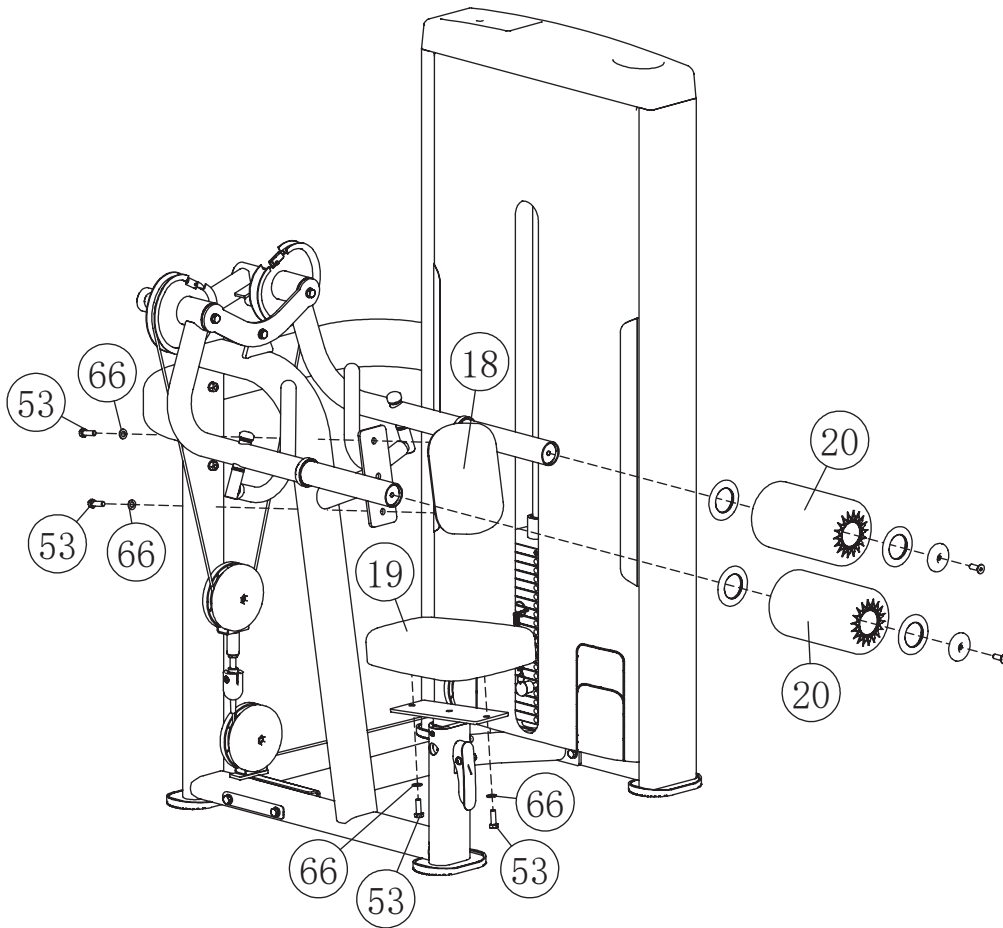

# Maintenance Schedule

| ROUTINE  | COMMERCIAL<br>MAINTENANCE | HOME<br>MAINTENANCE | LATEST DATE ENTRY |  |  |  |  |  |  |
|--|---------------------------|---------------------|-------------------|--|--|--|--|--|--|
|  |                           |                     |                   |  |  |  |  |  |  |
| Inspect;<br>Links, Pull Pins, Snap Locks,<br>Swivels, Weight Stack Pins              | DAILY                     | WEEKLY              |                   |  |  |  |  |  |  |
| Clean;<br>Upholstery   | DAILY                     | WEEKLY              |                   |  |  |  |  |  |  |
| Inspect;<br>Cables or Belts and their tension  | DAILY                     | WEEKLY              |                   |  |  |  |  |  |  |
| Inspect;<br>Accessory Bars, and Handles  | WEEKLY                    | 3 MONTHS            |                   |  |  |  |  |  |  |
| Inspect;<br>All Decals   | WEEKLY                    | 3 MONTHS            |                   |  |  |  |  |  |  |
| Inspect;<br>All Nuts and Bolts, Tighten if<br>needed                                 | WEEKLY                    | 3 MONTHS            |                   |  |  |  |  |  |  |
| Inspect;<br>Anti-Skid Surface  | WEEKLY                    | 3 MONTHS            |                   |  |  |  |  |  |  |
| Clean & Lubricate;<br>Guide Rods with a Teflon (PTFE)<br>based lubricant (Superlube) | MONTHLY                   | 3 MONTHS            |                   |  |  |  |  |  |  |
| Lubricate;<br>Seat Sleeves, Turcite Bushings,<br>Linear Bearing                      | MONTHLY                   | 3 MONTHS            |                   |  |  |  |  |  |  |
| Clean and Wax;<br>All Glossy Finishes  | 6 MONTHS                  | YEARLY              |                   |  |  |  |  |  |  |
| Repack with Grease;<br>Linear Bearings   | 6 MONTHS                  | YEARLY              |                   |  |  |  |  |  |  |
| Replace;<br>Cables, Belts and Connecting<br>Parts                                    | YEARLY                    | 3 YEARS             |                   |  |  |  |  |  |  |

*Your equipment comes with a commercial maintenance decal. For personal, in home use, please follow the home maintenance schedule listed above.*

## General Maintenance Information

### **Links, Pull-Pins, Snap Hooks, Swivels, Weight Stack Pins:**

- \* Check all pieces for signs of visible wear or damage.
- \* Check springs in snap hooks and pull-pins for proper tension and alignment.
- \* If the spring sticks or has lost its rigidity, replace it immediately.

### **Upholstery:**

- \* To ensure prolonged upholstery life and proper hygiene, all upholstered pads should be wiped down with a damp cloth after every workout.
- \* Periodically take the time to use a mild soap or an approved vinyl upholstery cleaner to deter the onset of cracking or drying. Avoid using any abrasive cleaners or cleaners not intended for use on vinyl.
- \* Replace ripped or worn upholstery immediately.
- \* Keep sharp or pointed objects clear of all upholstery.

### **Decals:**

- \* Inspect and familiarize yourself with any safety warnings or other user information posted on each decal.

### **Nuts and Bolts:**

- \* Inspect all nuts and bolts for any loosening and tighten if needed.
- \* Go through a re-tightening sequence periodically to ensure that all hardware is tensioned proper.

### **Anti-Skid Surfaces:**

- \* These surfaces are designed to supply secure footing and need to be replaced if they appear worn or become slippery.

### **Belts and Cables:**

- \* We use only high quality belt, and mil-spec cables.
- \* Visually inspect the belts and cables for fraying, cracking, peeling or discoloration.
- \* While the machine is not in use, carefully run your fingers along the belt or cable to feel for thinning or bulging areas.
- \* Replace belts and cables immediately at the first signs of damage or wear. Do not use equipment until belts or cables have been replaced.

### **Belt and Cable Tension:**

- \* Referring to the Owners Manual, when belts or cables are used check all bolts attachments to be sure they are properly attached.
- \* Check slack in cables and re-adjust cable tension if needed.

### **Seat Sleeves, Guide Rods:**

- \* Wipe down adjusting tubes with a dust free rag before applying lubricant.
- \* Lubricate seat sleeves and Guide Rods with a Silicon or Teflon based lubricant spray.

### **Linear Bearings:**

- \* Referring to the Owners Manual carefully disassemble the bearing from its housing and place a finger full of light grease (lithium, super lube, etc.) into the inside of the bearing. Using your finger, press the grease into the ball-bearings and their tracks. Repeat until the ball-bearing tracks are full of grease. Insert the shaft back into the bearing and wipe off excess grease.

**PLEASE KEEP THIS FOR YOUR RECORDS**

## Weight Training Tips

Use this manual to guide you through the basic exercises you can perform on your equipment. To gain maximum results and avoid possible injury, consult a fitness professional to develop your complete exercise program.

Always consult your physician before starting any exercise program.

To be successful in your exercise program, it is important to develop an understanding of the basic principles of strength training. Now that you have your equipment, it is only natural that you want to get started immediately. First, determine a set of realistic goals and objectives for yourself. By deciding on an exercise plan that is right for you prior to starting, you will contribute significantly to your success.

Warm up properly before engaging in weight resistance training. Stretching, yoga, jogging, calisthenics or other cardiovascular exercise can help prepare your body for the heavier workload of lifting weights.

Learn how to perform the exercise correctly before using heavy weight. Correct form is important to avoid injury and to ensure that you work the proper muscle groups.

Know your limitations. If you are new to weight training or are embarking on an exercise regimen after a long layoff, start slowly and build foundational strength over a longer period of time.

Pay attention to your breathing. Exhale when you exert is a general rule of thumb. Never hold your breath.

